

# PRODUCT DATA SHEET

PROKOSCH Pinch Valves  
Model 500



The PROKOSCH Series 500 pneumatically actuated pinch valves are designed specially for use in pneumatic conveying systems, also with abrasive media. They are characterised by their robustness, the use of fewer individual parts and space-saving elements, as well as their maintenance-free design. As the valve can be disassembled without special tools, the periodic replacement of the sleeve can be performed with little effort.

The free cylindrical passage reduces flow resistance to a minimum. The housing is made of light metal with generously dimensioned wall thicknesses. The body design has been tested with test pressures in excess of 24 bar at our factory.

On request, the sleeve can also be supplied in white food-grade quality and the flanges in stainless steel. Special designs with regard to the materials used and the construction are possible on request.

## Specifications

Nominal diameter	DN50...DN150
Max. operating pressure	6 Bar
Recommended control pressure	2 bar over operating pressure
Connections, on both sides	Flange DIN 1092-1
Temperature range	-20°C...+80°C

## Material Selection

Housing	Aluminium, optionally <input type="checkbox"/> powder coated
Flanges	Cast iron, optionally <input type="checkbox"/> powder coated or <input type="checkbox"/> stainless steel
Sleeve	NR, optionally <input type="checkbox"/> food grade

## Abmessungen

	DN	PN	LW	L	D	K	d	i	H	Weight
<input type="checkbox"/>	50	6	47	205	165	125	18	4	64	3,3 kg
<input type="checkbox"/>	65	6	62	205	185	145	18	4	74	4,7 kg
<input type="checkbox"/>	80	6	78	225	200	160	18	8	81	6,1 kg
<input type="checkbox"/>	100	6	97	280	220	180	18	8	91	7,9 kg
<input type="checkbox"/>	125	6	120	348	250	210	18	8	112	17,6 kg
<input type="checkbox"/>	150	6	144	418	285	240	22	8	128	26,6 kg

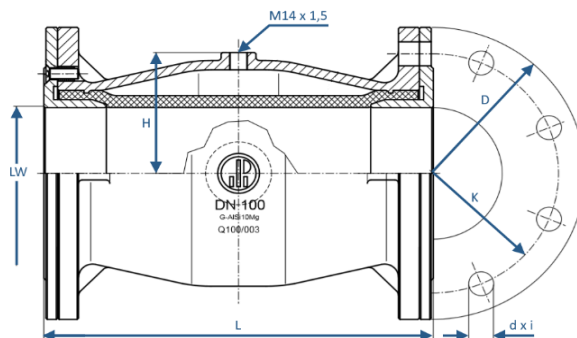

**PROKOSCH Pumpen und Armaturen GmbH**

In der Breitwiese 9, DE-76684 Östringen, Germany  
Phone +49 7259 9103 0 - Telefax +49 7259 9103 49  
contact us at [www.prokosch.de](http://www.prokosch.de) - [sales@prokosch.de](mailto:sales@prokosch.de)