

Data Sheet

Actuator Mounting Kit For Series 4 PROKOSCH Ball Valves



Mounting kit designed for mounting pneumatic, electric or Hydraulic actuators on PROKOSCH series 4 ball valves. The valve connection side of the bracket is drilled to PROKOSCH standard and the Actuator side is drilled to ISO 5211 Standard. The mounting kit includes the bracket, the shaft adapter and the necessary screws and washers required for connecting the mounting bracket to the valve and the actuator to the bracket.

Specifications

Article No.:	Suitable for	Adapter*	H4**	Actuator
SET00000180	DN40/DN50	17/14	ca. 18 mm	F05/F07
SET00000158	DN40/DN50	17/17	ca. 18 mm	F05/F07
SET00000157	DN65/DN80	19/17	ca. 20 mm	F07/F10
SET00000167	DN65/DN80	19/22	ca. 20 mm	F07/F10
SET00000159	DN100	27/22	ca. 24 mm	F10/F12
SET00000175	DN100	27/27	ca. 24 mm	F10/F12
SET00000259	DN125	27/22	ca. 24 mm	F10/F12
SET00000262	DN125	27/27	ca. 24 mm	F10/F12
SET00000033	DN150	35/27	ca. 24 mm	F12
SET00000096	DN150	35/36	ca. 30 mm	F14

Other adapter and bracket variations as also materials are available on request.

* Wrench size (SW) of the square-socket (valve) and the square spindle (Actuator).

** H4 refers to the dimension as indicated in the below illustration.

Materials

Mounting Bracket	stainless steel 304 equivalent*
Shaft Adapter	stainless steel 304 equivalent
Screws	galvanized steel
Washers	galvanized steel

* The material of mounting brackets for DN150 valves is steel

Dimensions for Valves DN40 to DN125

DN	40/50	65/80	100	125
A	58	66	80	78
A'	58	66	80	68
B	14	15,5	20	22,5
B'	14	15,5	20	15
SW	17	19	27	27
D	39	45	56	56
G	M8	M8	M8	M10
t	12	13	13	18
H1	6	7	7	7
H2	27	30	38	41
H3	60	60	60	60
W	101	120	140	140

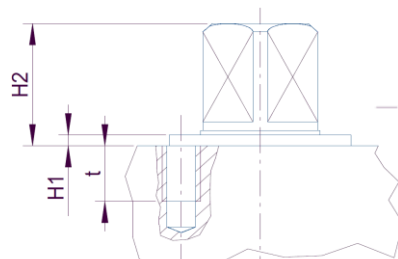

Valve top flange

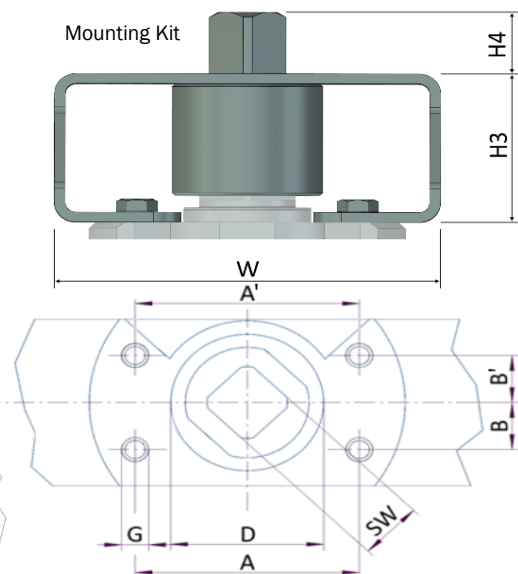

All information is subject to change and non-binding